

| | | | | | |
|--|--|--|--------------------------------|---|-----------------------------------|
| ramsey <small>THE INFORMATION CONTAINED IN THIS DRAWING IS THE SOLE PROPERTY OF RAMSEY ELECTRONICS. ANY REPRODUCTION IN PART OR AS A WHOLE WITHOUT THE WRITTEN PERMISSION OF RAMSEY ELECTRONICS IS PROHIBITED.</small> | <small>UNLESS OTHERWISE SPECIFIED:</small> DIMENSIONS ARE IN INCHES TOLERANCES: FRACTIONAL ± 1/64 DECIMAL ± .01 ANGULAR ± 30 MIN HOLE POSITION ± .015 TWO PLACE DECIMAL ± .01 THREE PLACE DECIMAL ± .005 | <small>NAME</small> J TANDLE | <small>DATE</small> 5/19/23 | Ramsey Electronics® 590 Fishers Station Dr. Victor, NY 14564 Ph. (585) 924-4560 TITLE: STE4491M CUSTOMER DIMENSIONAL DRWG SIZE DWG. NO. REV D STE4491M CUSTOMER DIMENSIONAL DRWG A MODEL NAME: STE4491M CUSTOMER DIMENSIONAL DRWG SCALE: 1:8 SHEET 1 OF 2 | |
| | <small>FINISH</small> DO NOT SCALE DRAWING | <small>INTERPRET GEOMETRIC TOLERANCING PER ASME Y14.5-2009</small> | <small>CHECKED</small> PMT | | <small>DATE</small> 5/24/23 |
| | | <small>ENG APPR.</small> - | <small>DATE</small> - | | <small>ENG APPR.</small> - |
| | | <small>FINAL RELEASE</small> - | <small>DATE</small> - | | <small>FINAL RELEASE</small> - |

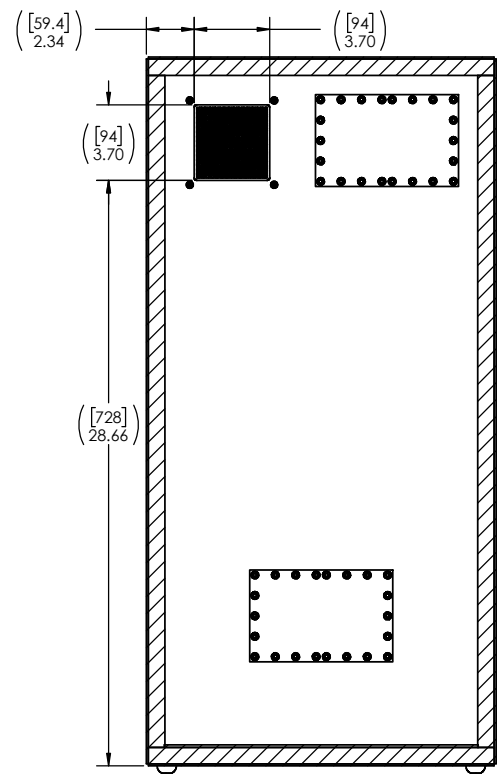

SECTION A-A

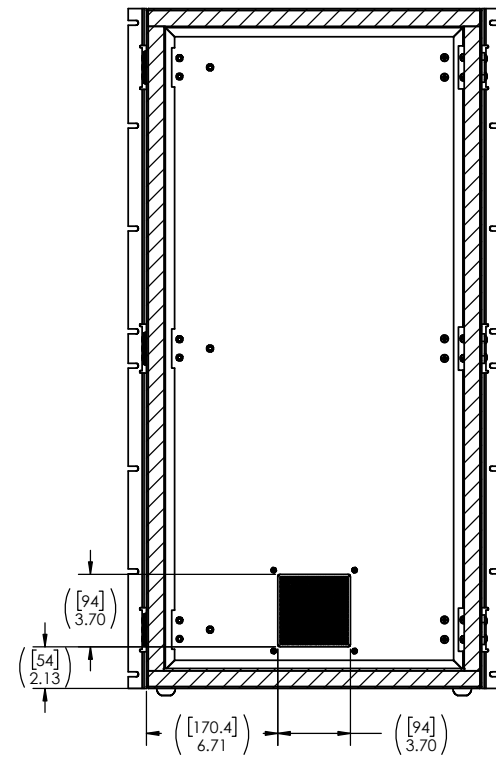

SECTION E-E
SCALE 1 : 4.9

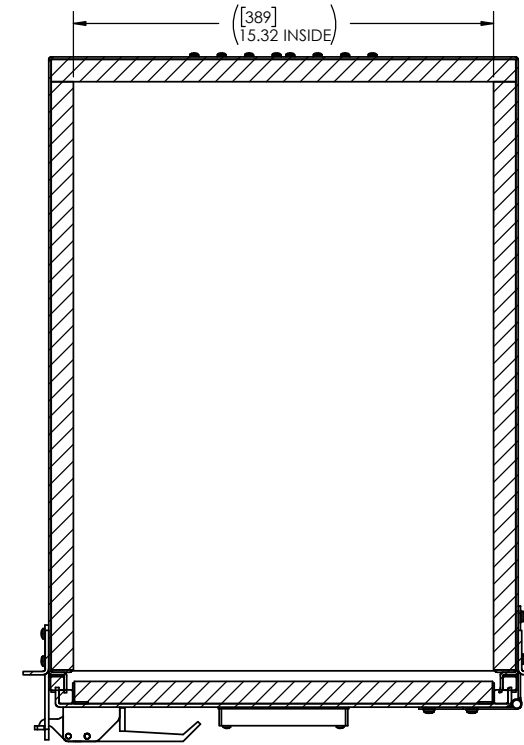

SECTION B-B

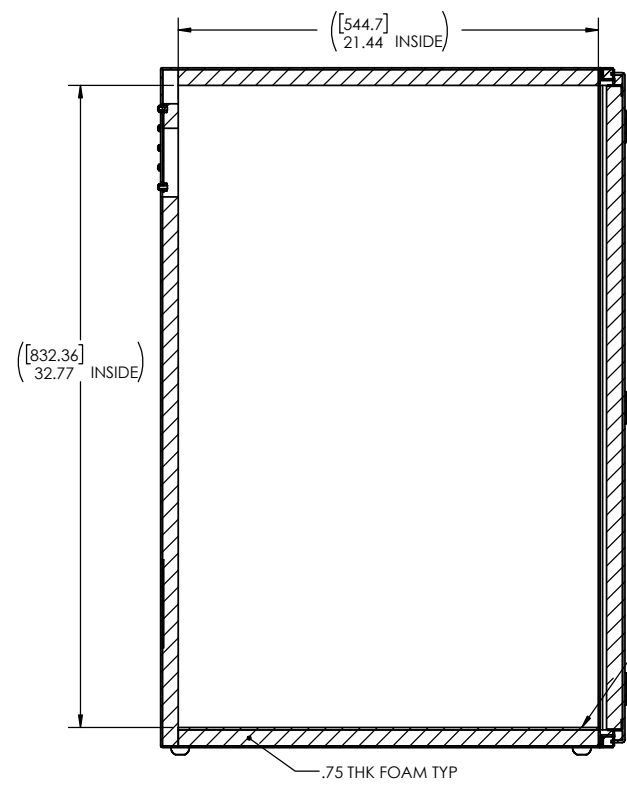

SECTION C-C
SCALE 1 : 4.9

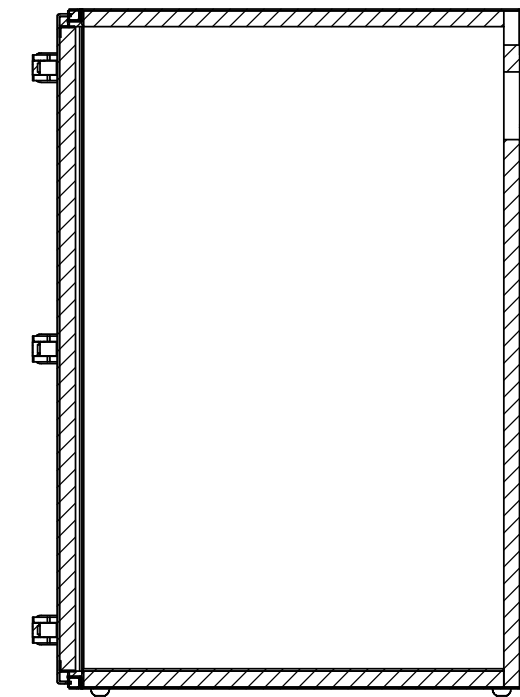

SECTION D-D
SCALE 1 : 4.9

| | | | | | |
|---|---|--|---|---|---------------------------|
| PROPRIETARY AND CONFIDENTIAL THE INFORMATION CONTAINED IN THIS DRAWING IS THE SOLE PROPERTY OF RAMSEY ELECTRONICS. ANY REPRODUCTION IN PART OR AS A WHOLE WITHOUT THE WRITTEN PERMISSION OF RAMSEY ELECTRONICS IS PROHIBITED. | DIMENSIONS ARE IN INCHES TOLERANCES: FRACTIONAL ± 1/64 ANGULAR MATCH ± 0.01 TWO PLACE DECIMAL ± .01 THREE PLACE DECIMAL ± .005 | NAME J TANDLE | DATE 5/19/23 | Ramsey Electronics® 590 Fishers Station Dr. Victor, NY 14564 Ph. (585) 924-4560 | |
| | INTERPRET GEOMETRIC TOLERANCING PER ASME Y14.5-2009 | CHECKED ENG APPR. IMRG APPR. FINAL RELEASE | COMMENTS: | | TITLE: STE4491M |
| | FINISH DO NOT SCALE DRAWING | MODEL NAME: STE4491M CUSTOMER DIMENSIONAL DRWG | SCALE: 1:8 | | SHEET 2 OF 2 |
| | CUSTOMER DIMENSIONAL DRWG | | DWG. NO. STE4491M CUSTOMER DIMENSIONAL DRWG | | REV A |